



INVITATION TO BID

The Arlington Heights Park District will receive sealed bids for: **Tracked Boom Lift** at the Park District office at 410 N. Arlington Heights Road, until **1:00 PM on May 11, 2023**. A public opening will take place at **1:00 PM on May 11, 2023** at the Park District office at 410 N. Arlington Heights Rd., Arlington Hts., IL. 60004. The Bid may be awarded at the Park Board Meeting on **May 25, 2023** at 6:30 p.m. at the Administration Center.

Copies of documents required for bidding can be downloaded from our website: <https://www.ahpd.org/capital-improvements/rfps-and-bids/>.

Bidders must note:

1. Proposals are to be enclosed in a sealed envelope addressed to: Arlington Heights Park District, 410 N. Arlington Heights Road, Arlington Heights, Illinois 60004, **Attention: "Bid Dept. Tracked Boom Lift"**.
2. Bids shall be submitted only on the bid form provided. The bid form must be completed in full and all total prices must include all work as stated in the specifications.
3. All bids submitted will be considered firm for a period of 60 days from the bid opening date.
4. All bidders are required to demonstrate to the satisfaction of the Park District, that they are capable and able to complete the work as required in the specifications. Each bidder shall submit with his bid, proof that he satisfactorily performed work of a similar nature to that specified within the preceding two years, together with the locations and the names of the responsible individuals in charge of such projects.

The Board of Park Commissioners of the Arlington Heights Park District reserves the right to waive any irregularities and to accept or reject any proposal.

By Order Of: Board of Park Commissioners
Arlington Heights Park District



INSTRUCTIONS TO BIDDERS

1. The following information is enclosed in your Bid Packet.
 - Instructions to Bidders
 - Invitation to Bid
 - Bid Form
 - Agreement Form
 - Anti Collusion, Sexual Harassment, Illinois Drug Free Affidavits
 - Specifications
 - Detail Specifications (if any)
 - Addenda (if any)
 - Conditions of the bid

2. Please read through the material carefully. All figures must be presented on the Bid Form in order to be considered. Information from any other source will be considered supplemental and not as a part of the bid itself.

3. The following items are to be returned as your completed bid:
 - Bid Form - containing all totals
 - Agreement - with the bidder's name completed on line two
 - Signed Anti-Collusion Affidavit, Sexual Harassment, Illinois Drug Free Affidavits
 - Specifications
 - Detailed Specifications (if any)
 - Addenda (if any)
 - Conditions of the Bid

Date: 4/28/2023

Bid Documents For: Tracked Boom Lift

Project: The scope of work involves furnishing all of the required labor, materials, equipment, or parts and supplies in accordance with the plans, specifications and drawings dated **4/28/2023** and any authorized change orders there to which have been signed by both parties hereto, and which are hereby incorporated herein by reference.

Location: **Davis Service Center**
1436 E. Davis St.
Arlington Hts., IL
60005

Owner: Arlington Heights Park District
410 N. Arlington Heights Road
Arlington Heights, IL 60004
(847) 577-3000

Contact Person: Benjamin M. Rea, Dir. Of Parks and Planning 847-506-7145

Bid Opening: All bids are due no later than **1:00 PM** on **May 11, 2023** at 410 N. Arlington Heights Rd., Arlington Heights, IL 60004. Bids shall be submitted in sealed envelopes, plainly marked: **"Attn: Bid Dept- Tracked Boom Lift"**

REFERENCES:

List three clients for reference checks. Bidder must have supplied equipment of a similar nature for these clients within the last two years.

<u>Company Name</u>	<u>Contact Person</u>	<u>Phone Number</u>
1. _____	_____	_____
2. _____	_____	_____
3. _____	_____	_____

In compliance with the invitation for bids, and subject to all the conditions thereof, the undersigned offers, and agrees, if this bid be accepted within sixty (60) days from the date of the opening, to furnish any or all of the items upon which prices are quoted, at the price set opposite each item and, unless otherwise specified within sixty (60) days after receipt of order.

Date: _____

(Please Print)
Name of Bidder _____

Address _____

Phone Number _____

Authorized Signature

Name and Title



AGREEMENT

This Agreement made this _____ day of _____, 20_____, by and between _____, hereinafter called the "CONTRACTOR" and the ARLINGTON HEIGHTS PARK DISTRICT, hereinafter called the "PARK DISTRICT".

WITNESSETH, that the CONTRACTOR and the PARK DISTRICT for the consideration stated here-in agree as follows:

ARTICLE I - SCOPE OF WORK: The CONTRACTOR shall provide all of the materials and perform all of the work described in the specifications entitled:

Tracked Boom Lift

and in strict accordance with the requirements of all of the component parts of this Agreement as noted under Article V, all of which are attached hereto and made a part hereof.

ARTICLE II - TIME OF COMPLETION: This purchase will be made under this agreement and shall be **received by: June 30, 2023.**

ARTICLE III - CONTRACT PRICE: The PARK DISTRICT shall make payments to the CONTRACTOR for the completed performance of work included in this agreement in compliance with the prices as noted in the proposal dated **05/11/2023** and in accord with subsequent approved agreement change orders subject to all of the provisions of the component parts of this agreement.

Base Bid \$ _____

ARTICLE IV - COMPLIANCE WITH LAW: The CONTRACTOR shall comply with all statutes, rules and regulations of all Federal, State and Local Agencies having jurisdiction over the proposed improvement at the time the proposal was submitted to the PARK DISTRICT. Any and all costs associated in complying with said statutes, rules and regulations in effect at the time proposals were submitted and due shall be included within the costs of the proposal submitted.

ARTICLE V - COMPLIANCE WITH ADA: In addition to the obligations set forth in Article IV, the contractor confirms that the materials and/or products listed in the proposal for bid do comply with the Americans with Disabilities Act, Title II, the ADA Accessibility Guidelines, the Illinois Accessibility Code, and all rules and regulations promulgated with reference thereto. In addition, if the contractor is obligated by this agreement to install the materials and/or products, the contractor shall install the materials and/or products in compliance with the Americans with Disabilities Act, Title II, ADA Accessibility Guidelines, the Illinois Accessibility Code, and all rules and regulations promulgated with reference thereto. All costs of compliance with said statutes, rules and regulations in effect at the time the contractor submitted its bid have been included in the contract price.

ARTICLE VI - COMPONENT PARTS OF THIS AGREEMENT: This agreement consists of the following component parts, all of which are as fully a part of this agreement as if herein set out verbatim, or if not attached, as if attached hereto:

Instruction to Bidders

Invitation to Bid
Bid Form
This Agreement
Anti-Collusion, Sexual Harassment, Illinois Drug Free
Affidavits
Contractor's Certification
Specifications
Detailed Specifications (if any)
Addenda,(if any)
Conditions of the Bid

In the event that any provisions in any of the above component parts of the agreement conflict with any provision in any other component parts, the provision in the component part last enumerated above shall govern over any other component part which precedes it numerically, except as may otherwise specifically stated.

IN WITNESS WHEREOF, the parties hereto have caused this instrument to be executed in three (3) original counterparts the day, month and year first above written.

CONTRACTOR: _____

ADDRESS: _____

SIGNATURE: _____ TITLE: _____

Attest: _____ Title: _____

(SEAL)

PARK DISTRICT

ARLINGTON HEIGHTS PARK DISTRICT

SIGNATURE: _____ TITLE: _____

Date:

ARLINGTON HEIGHTS PARK DISTRICT

ANTI-COLLUSION AFFIDAVIT AND CONTRACTOR'S CERTIFICATION

_____, being first duly sworn, deposes and says:

That he is _____ of
(Partner, Officer, Owner, etc.)

(Contractor)

The party making the foregoing proposal or bid, that such bid is genuine and not collusive, or sham; that said Bidder has not colluded, conspired, connived or agreed, directly or indirectly, with any Bidder or person, to put in a sham bid or to refrain from bidding, and has not in any manner, directly or indirectly, sought by agreement or collusion, or communication or conference with any person; to fix the bid price element of said bid, or of that of any other bidder, or to secure any advantage against any other bidder or any person interested in the proposed contract.

The undersigned certifies that he is not barred from bidding on this contract as a result of a conviction for the violation of State laws prohibiting bid-rigging or bid-rotating.

(Name of Bidder if the Bidder is an Individual)
(Name of Partner if the Bidder is a Partnership)
(Name of Officer if the Bidder is a Corporation)

The above statements must be subscribed and sworn to before a notary public. Subscribed and sworn to this _____ day of _____, 20____.

ARLINGTON HEIGHTS PARK DISTRICT
SEXUAL HARASSMENT POLICY

The undersigned, on behalf of the entity making this proposal or bid, certified that a written sexual harassment policy is in place, pursuant to Public Act 87-1257, effective July 1, 1993, 775 ILCS 5/2-105 A).

This Act has been amended to provide that every party to a public contract must have a written sexual harassment policy that includes, at a minimum, the following information:

1. The illegality of sexual harassment;
2. The definition of sexual harassment, under State law;
3. A description of sexual harassment, utilizing examples;
4. The vendor's internal complaint process including penalties;
5. The legal recourse, investigative and complaint process available through the Department of Human Rights and the Human Rights Commission;
6. Directions on how to contact the Department and Commission;
7. Protection against retaliation as provided by 6-101 of the Act.

IT IS EXPRESSLY UNDERSTOOD THAT THE FOREGOING STATEMENTS AND REPRESENTATIONS AND PROMISES ARE MADE AS A CONDITION TO THE RIGHT OF THE BIDDER TO RECEIVE PAYMENT UNDER AND AWARD MADE UNDER THE TERMS AND PROVISION OF THIS BID.

SIGNATURE: _____

NAME: _____ TITLE: _____

ARLINGTON HEIGHTS PARK DISTRICT

ILLINOIS DRUG FREE WORK PLACE STATEMENT

The undersigned will publish a statement:

1. Notify employees that the unlawful manufacture, distribution, dispensation, possession or use of a controlled substance is prohibited in the work place;
2. Specifying the actions that will be taken against employees for violating this provision;
3. Notifying the employees that, as a condition of their employment to do work under the contract with the Arlington Heights Park District, the employee will:
 - a) Abide by the terms of the statement;
 - b) Notify the undersigned of any criminal drug stature conviction for a violation occurring in the work place not later than five (5) days after such a conviction;
4. Establishing a drug free awareness program to inform employees about:
 - a) The dangers of drug abuse in the work place;
 - b) The policy of maintaining a drug-free work place;
 - c) Any available drug counseling, rehabilitation or employee assistance program;
 - d) The penalties that may be imposed upon an employee for drug violations;
5. The undersigned shall provide a copy of the required statement to each employee engaged in the performance of the contract with the Arlington Heights Park District, and shall post the statement in a prominent place in the work place;
6. The undersigned will notify the Arlington Heights Park District within ten (10) days of receiving notice of an employee’s conviction;
7. Make a good faith effort to maintain a drug free work place through the implementation of these policies;
8. The undersigned further affirms that within thirty (30) days after receiving notice of a conviction of a violation of the criminal drug statue occurring in the work place, he shall:
 - a) Take appropriate action against such employee up to and including termination; or
 - b) Require the employee to satisfactorily participate in a drug abuse assistance or rehabilitation program approved for such purposed by a federal, state, or local health, law enforcement, or other appropriate agency;

IT IS EXPRESSLY UNDERSTOOD THAT THE FOREGOING STATEMENTS AND REPRESENTATIONS AND PROMISES ARE MADE AS A CONDITION TO THE RIGHT OF THE BIDDER TO RECEIVE PAYMENT UNDER ANY AWARD MADE UNDER THE TERMS AND PROVISIONS OF THIS BID.

SIGNATURE _____
 NAME: _____ TITLE: _____
 Date: _____

ARLINGTON HEIGHTS PARK DISTRICT

II. CONDITIONS OF THE BID

DEFINITION OF TERMS

Throughout these bid documents, the following terms shall be used:

- Bidder - Any individual, firm, company or corporation submitting a sealed proposal as a bid on the designated item(s) or project.
- Contractor - Any individual, firm, company or corporation whose bid is accepted by the Arlington Heights Park District for the item(s) or project.
- Executive Director - The Executive Director of the Arlington Heights Park District or his designated representative.
- Park District - The Arlington Heights Park District of Cook and Lake Counties, Illinois.

FORMS

All bid proposals are to be submitted on the Bid Form provided, signed in ink in the proper spaces and submitted in a marked and sealed envelope.

PRE-BID CONFERENCE AND QUESTIONS

There is no pre-bid meeting. If any questions arise about the Bid documents, they should be directed, in writing, to the Park District. All questions and responses will be available to all interested persons through the Park District.

When an error is made in extending the total price, the unit price will govern. Otherwise the bidder is not relieved from errors in bid preparation.

CORRECTIONS/WITHDRAWAL

If an error is found in a bid, it must be corrected before the date and time for the bid opening. A written request for withdrawal of the original bid or any part thereof may be granted only if the request is received prior to the specified time of closing. No bid may be withdrawn or canceled after the closing time for receipt of bids and for a period of sixty (60) days thereafter.

TRADE NAMES

When an item is identified in the specifications by a manufacturer's or trade name or catalog number, the Bidder shall bid upon the item so identified. If the specifications state "or equal," bids on other items will be considered, provided the Bidder clearly identifies in his proposal the item to be furnished, together with any descriptive matter which will indicate the character of the item.

The Park District shall have the right to approve or reject as an equal, any article the Bidder proposes to furnish which contains variations from the specifications.

PRICE

1. Bidders must specify unit prices as well as the aggregate price, unless otherwise specified. Failure to specify unit prices when required may result in bid rejection.
2. Cash Discount - Offers of cash discounts will be considered in determining awards.

TAXES

This work is being done under the auspices of the Arlington Heights Park District and therefore is exempt from the Illinois sales tax and the Regional Transportation Authority sales tax. The proposal shall not include any costs for these taxes.

DELIVERY CHARGES

All bid prices should include both shipping and delivery charges. These charges shall be freight (F.O.B.) to the Park District. **Delivery to: Davis Service Center, 1436 E. Davis St., Arlington Hts., IL 60005. Davis Service Center owned and operated by the Arlington Heights Park District.**

PAYMENT

Payment will be made to the Contractor within thirty (30) days of completion and acceptance of the project by the Park District. As required by the IRS, a **W-9 Request For Taxpayer** Identification Number and Certification Form must be submitted to the accounting department along with a Vendor Application prior to releasing payment for the project. IRS form, Vendor Application and an ACH Authorization Form (for direct deposit payments) will be included with the Award Letter to the contractor awarded this project.

OMISSIONS AND DISCREPANCIES

Should a Bidder find discrepancies in, or omissions from bid documents, he should at once notify the Arlington Heights Park District which may send a written instruction to all Bidders.

ACCEPTANCE OR REJECTION OF BIDS

The Park District reserves the right to reject any or all bids, to award a contract for only a portion of the bid work, waive informalities or technicalities in any bid, and accept any bid it deems to be in its best interest.

The Park District may consider such factors as bid price, delivery guarantee, experience and responsibility of bidder, methods of construction and similar factors in determining which bid it deems to be in its best interest.

GUARANTEE

The Bidder shall guarantee, in writing, that all materials and workmanship are free from defects and will remain so free for a period of at least one year after completion of the work. He shall further agree to replace all defective materials furnished under this agreement for a period of one year from the date of final acceptance, at no additional charge to the District.

ANTI-COLLUSION AFFIDAVIT

Bidders shall file an affidavit of anti-collusion, contained herein, with all bids for award consideration.



BID FORM

ARLINGTON HEIGHTS PARK DISTRICT
410 N. ARLINGTON HEIGHTS ROAD
ARLINGTON HEIGHTS, IL 60004
(847) 577-3000

<u>4/28/2023</u>	<u>5/11/2023</u>	<u>6/30/2023</u>
DATED	BID OPENING DATE	ACCEPTANCE DATE

Sealed bids will be received by the Arlington Heights Park District until **1:00 pm** on **May 11, 2023** and then publicly opened for furnishing the following supplies and/or services to be delivered in accordance with the following instructions:

Bid Opening at: Arlington Heights Park District Administration Center
410 N. Arlington Heights Road
Arlington Heights, IL 60004

The contractor shall be notified of purchase no later than **24 hours after Board approval**, and shall so order this equipment so the equipment is delivered and ready no later than **June 30, 2023**.

The bidder hereby acknowledges receipt of the following addenda, if any, distributed by the Arlington Heights Park District.

Addendum No. _____	Date _____
Addendum No. _____	Date _____
Addendum No. _____	Date _____

TOTAL BASE BID FOR:
Tracked Boom Lift

\$ _____

(IN WORDS) _____

DELIVERY OF MATERIALS TO: Davis Service Center

SPECIFICATIONS FOR

Tracked Boom Lift

ARLINGTON HEIGHTS PARK DISTRICT

ARLINGTON HEIGHTS, ILLINOIS

I DESCRIPTION OF BID REQUEST/MATERIALS

Provide a New 2023 CTE Traccess 230 with fiberglass bucket- per bid specifications

SEE ATTACHED SPECIFICATIONS

Any alterations or modifications of the work herein specified shall be made only by written agreement between the Bidder and the Park District, and shall be made prior to commencement of any such alterations or modifications. No claims for any extra work or materials will be allowed unless covered by written agreement.

All bids submitted will be considered firm for a period of 60 days from the bid opening date.

SPECIFICATIONS

- » 75 ft. working height
- » 39 ft. outreach at full bucket capacity of 441 lb.
- » 6,393 lb. machine weight
- » Articulated boom (two elements) + telescopic boom (main boom + 2 extension) + jib
- » Sigma boom movement enabled by connecting rods
- » 360° non continuous turret rotation on bearing turntable
- » Proportional electro-hydraulic controls in basket
- » Engine start and stop controls from basket
- » Fiberglass bucket
- » 90° right + 90° left hydraulic basket rotation (option)
- » Basket load sensing device
- » Radio remote control
- » Dual drive speed
- » Narrow jacking facility
- » Extending width tracks
- » 110V 2.2 kW electric auxiliary motor
- » Automatic hydraulically actioned basket levelling
- » N° 4 hydraulic outriggers with ground pressure sensors
- » Hour meter
- » 110 V AC EC electrical socket in the basket
- » Standard boom colours blue (RAL 5017) or white (RAL 9003)
- » EN 280:2013 CE certified
- » Gradeability approximately 31%
- » Electro-hydraulic steering from the ground with radio control
- » Drive speed max 1.25 mph
- » 4 stabilization areas with hydraulic placement
- » Kubota diesel engine and 30 amp 120 volt electric motor

OUTRIGGER FOOTPRINT

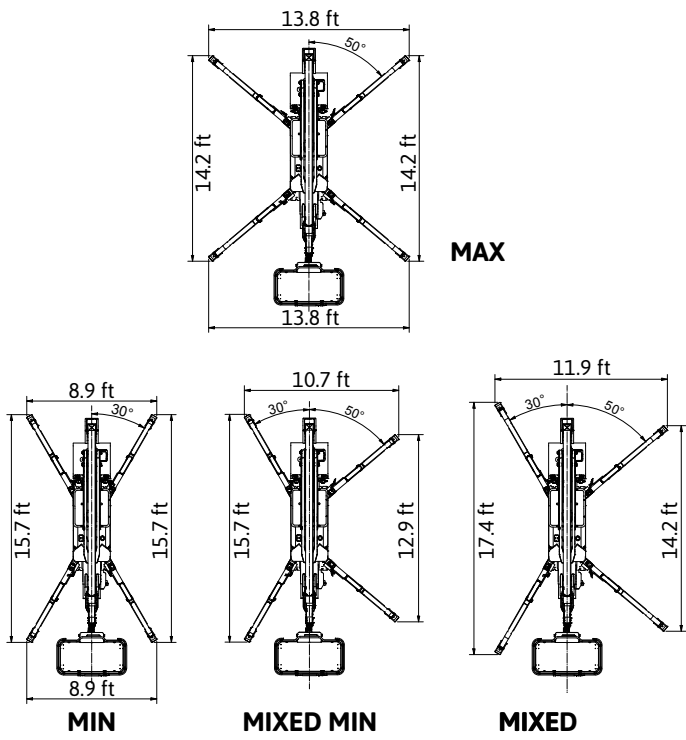

DIMENSIONS

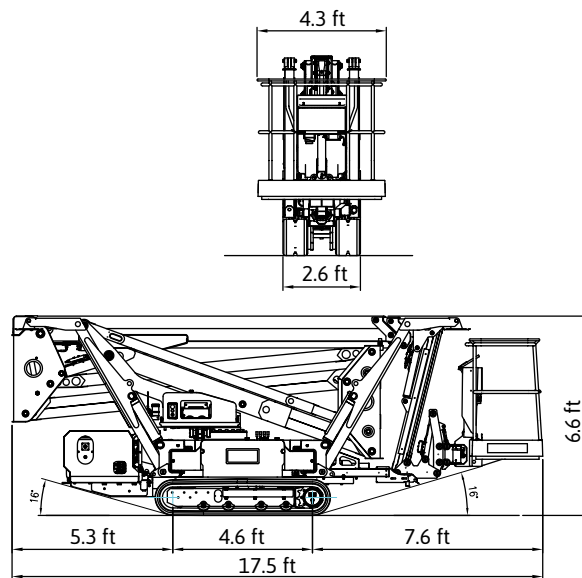

WORKING ENVELOPE

 ±320°

